

# Nichipet F & V

Fixed & Triple Volume Micro Pipettes

## User's Manual

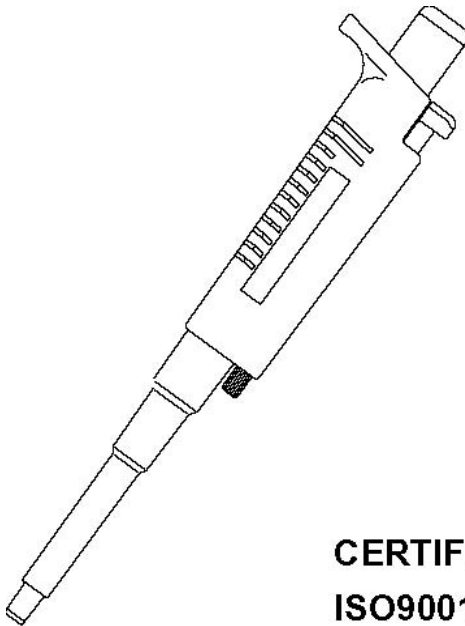

**CERTIFIED  
ISO9001**

- Thank you for your purchase of our Nichipet F&V.
- Before proceeding to work with your Nichipet F & V, carefully read this manual for proper use of it.

Always Pursuing Originality  
Since 1944



**NICHIRYO**

## FEATURES

- Thumb Plunger** : Smooth, effortless movement of the plunger reduces the operator's fatigue.
- Select Volume** : Volume change is simply achieved by just turning the thumb knob. The selected volume remains fixed. (Nichipet V)
- Tip Ejector Knob**: Built in tip ejector for the safe disposal of used tips. Knob location eliminates the possibility of accidental tip ejection.
- Body Design** : Lightweight, slender design reduces the operator's fatigue. Thermal insulation prevents body heat from contributing to measurement error during prolonged handling.
- Seal Ring** : Fluoroplastic seal and Rubber-O-Ring eliminate the need for routine maintenance and lubrication.
- Tip Ejector Pipe** : Non-Metallic Tip Ejector Body permits easy access to the bottom of commonly used test tubes.
- Cylinder** : Designed to minimize dead air space for increased pipette accuracy.

## SPECIFICATIONS / ORDERING INFORMATION

### Nichipet-V TRIPLE VOLUME

Cat.No.	Volume	Accuracy	Precision
NPV-S	10/20/50 $\mu$ L	$\pm 1.2 \sim \pm 0.7\%$	$\leq 0.6 \sim \leq 0.3\%$
NPV-M	50/100/200 $\mu$ L	$\pm 0.7 \sim \pm 0.5\%$	$\leq 0.4 \sim \leq 0.3\%$
NPV-L	200/500/1000 $\mu$ L	$\pm 0.7 \sim \pm 0.5\%$	$\leq 0.3 \sim \leq 0.2\%$

### Nichipet-F FIXED VOLUME (Standard Volume)

Cat.No.	Volume	Accuracy	Precision
NPF-5 (5 $\mu$ L) NPF-1000 (1000 $\mu$ L)	5, 10, 20, 25, 50 100, 200, 250, 300 500 & 1000 $\mu$ L	5 $\mu$ L : $\pm 1.5\%$	$\leq 0.5\%$
		10 $\mu$ L : $\pm 1.2\%$	$\leq 0.4\%$
		20 $\mu$ L $\sim$ 25 $\mu$ L : $\pm 0.8\%$	$\leq 0.3\%$
		50 $\mu$ L $\sim$ 300 $\mu$ L : $\pm 0.6\%$	$\leq 0.3\%$
		500 $\mu$ L $\sim$ 1000 $\mu$ L : $\pm 0.5\%$	$\leq 0.2\%$

## OPERATION

1. Select the desired volume on Nichipet V by turning the thumb knob until the desired volume figures on the thumb knob correspond to the arrow mark printed on the top of the pipette handle. (Fig. 1)
2. Place a disposable tip firmly onto the end of the pipette. Depress the thumb knob to the first stop. Dip the tip into the liquid to a depth of 3mm. (Step 1 of Fig. 2)
3. Smoothly return the thumb knob to its original position. The liquid will then be drawn into the tip. (Step 2)

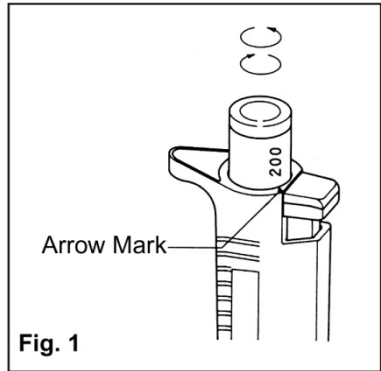

4. Touch the tip against the inside wall of the receiving vessel. (Step 3)
5. Smoothly depress the thumb knob to the first stop (step 4), pause: then depress the knob to the second stop (step 5).

**Note:** When dispensing serum and other viscous fluids, it is necessary to pause about two seconds before moving to the secondary stop.

6. Remove the used tip from the pipette by depressing the tip ejector knob.

(Step 6)

**Note:** Depress and release the thumb knob at constant speed to ensure good precision.

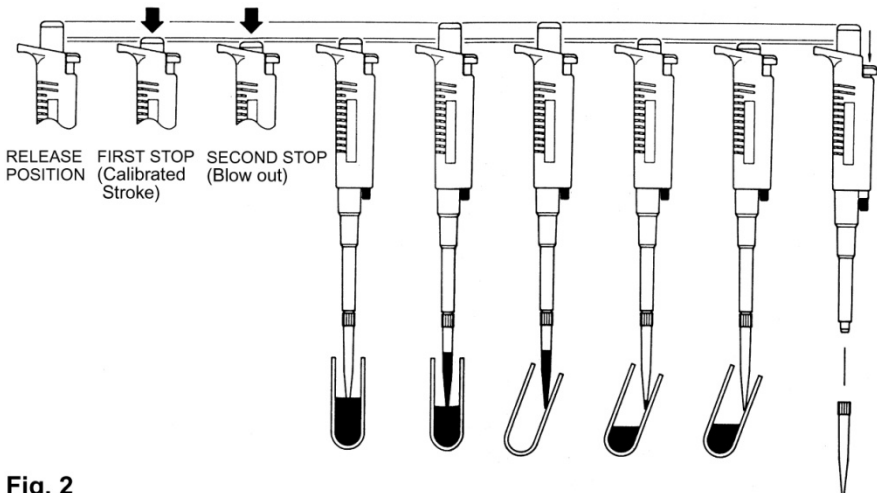

## AIDS TO PRECISION AND ACCURACY

Listed below are some techniques found to improve sampling precision. PLEASE READ THIS SECTION CAREFULLY.

1. Try to effect the same speed for both the intake and delivery of all samples. Smooth depression and release of the plunger knob will give the most consistent results. Never allow the plunger to “snap” back. Consistency of technique is a key to precision.
2. Always depress the thumb knob to the proper stop before insertion of the tip into the solution. Depression of the thumb knob after insertion may cause the formation of an air bubble in the tip and result in filling error.
3. Try to insert the tip to approximately the same depth in the sample each time, never going deeper than 3mm. Hold the instrument as vertically as possible (10° maximum from vertical).
4. When sampling hot or cold material, the tip temperature should be equalized to that of the solution to prevent contraction or expansion of solution.

## SERVICE AND MAINTENANCE INFORMATION

It is recommended that the following servicing procedures be performed at regular intervals. Heavy usage or usage with corrosive fluids will require more frequent servicing.

### Disassembly (Reference Figure 3 & 4)

1. Turn the screw bolt counterclockwise to remove a tip ejector pipe. Gently pull the tip ejector pipe off the end of tip ejector pipe during this procedure.
2. Unscrew the barrel assembly from the handle and carefully pull directly away from the handle. The plunger assembly and spring can be removed from the pipette. Refer to Figure 4 for the internal configuration of the pipette being serviced. Take special care not to bend the piston rod, especially in the smaller volume units.
3. Replace the O-ring.

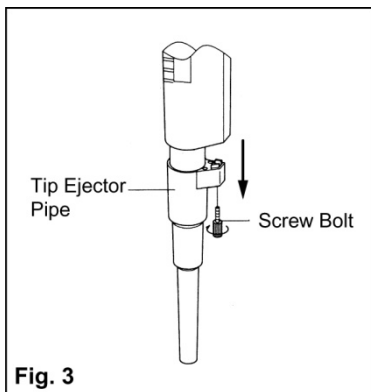

4. Reassemble the unit by reversing the above procedures. Refer to Figure 4 when reassembling to ensure that all parts are placed in the correct position.
5. To reassemble the tip ejector pipe gently push on the tip ejector pipe so that the pipe mates with the handle connection. Turn the screw clockwise to secure.
6. After the above maintenance procedure, should the feeling of a smooth piston stroke seem different from what it was before this procedure, immediately disassemble the pipette as in the above procedure and reassemble per the schematics in Figures 3 and 4.
7. After the above maintenance procedure, should the tip ejector knob stroke seem different and lack the smoothness of its normal stroke, immediately disassemble the tip ejector portion of the pipette and reassemble ensuring the spring and spring holder are installed properly.

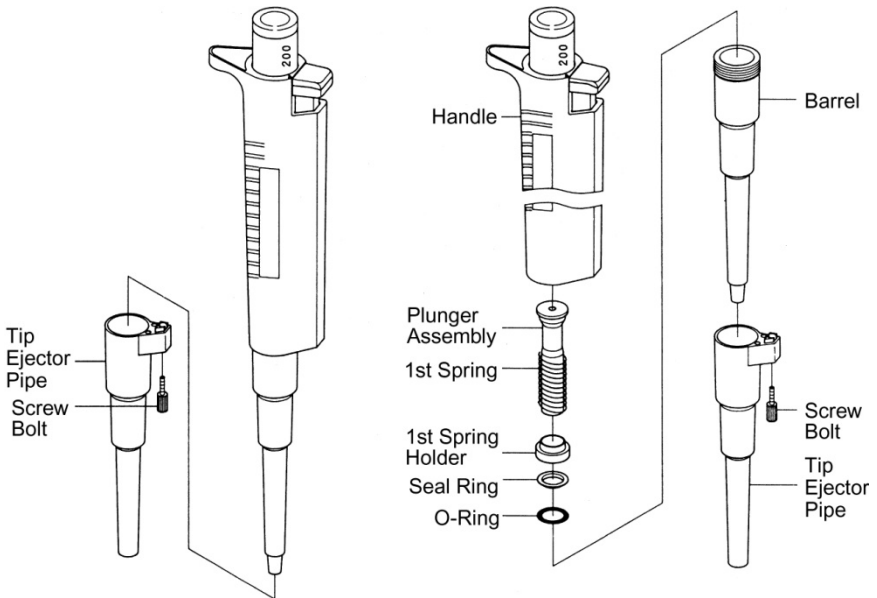

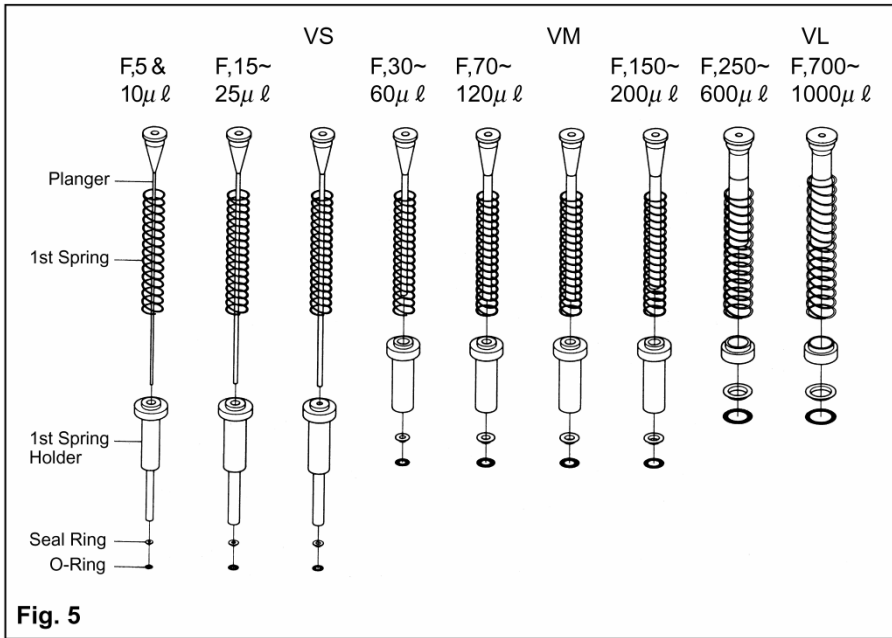

## ORDERING INFORMATION

### Nichipet-F Fixed Volume Pipette

Cat.No.	Volume	Accessories
NPF-5(5uL) to NPF-1000(1000uL)	5,10,20,25,50 100,200,250,300 500 & 1000uL	Appropriate tips

### Nichipet-V TRIPLE VOLUME

Cat.No.	Volume	Accessories
NPV-S	10/20/50 $\mu$ L	Appropriate tips
NPV-M	50/100/200 $\mu$ L	
NPV-L	200/500/1000 $\mu$ L	

### Tip (Autoclavable)

Cat.No.	Volume( $\mu$ L)	Color	Usable Model	Q'ty(bag)
BMT2-SS	0.5~10	Clear	NPF-5,10	1000
BMT2-SE	2~200	Clear	NPV-S,M NPF-15~200	1000
BMT2-SG	2~200	Clear	NPV-S,M NPF-15~200	1000
BMT2-LG	100~1000	Clear	NPV-L NPF-250~1000	1000

### Racked Tip (Autoclavable)

Cat.No.	Volume( $\mu$ L)	Color	Usable Model	Q'ty(box)
BMT2-SSR	0.5~10	Clear	NPF-5,10	960 (96pcs.x10c/s)
BMT2-SER	2~200	Clear	NPV-S,M NPF-15~200	960 (96pcs.x10c/s)
BMT2-SGR	2~200	Clear	NPV-S,M NPF-15~200	960 (96pcs.x10c/s)
BMT2-LGR	100~1000	Clear	NPV-L NPF-250~1000	960 (96pcs.x10c/s)

### Stand

Cat.No.	Description
BMT-STD (Acryl resin)	6 pipettes can be stored.

### Inspection and Calibration Statement

The enclosed pipette was tested and calibrated under closely controlled environmental conditions to ensure that it meets published calibration specifications.

The precision and accuracy results obtained for this pipette are provided on the enclosed calibration certificate.

Because temperature and humidity conditions affect the calibration results of liquid measurement devices, your pipette should be calibrated under conditions of use.

The calibration results obtained in your laboratory may vary from our results due to differences in environmental testing conditions.

For repair, service or information you may contact:

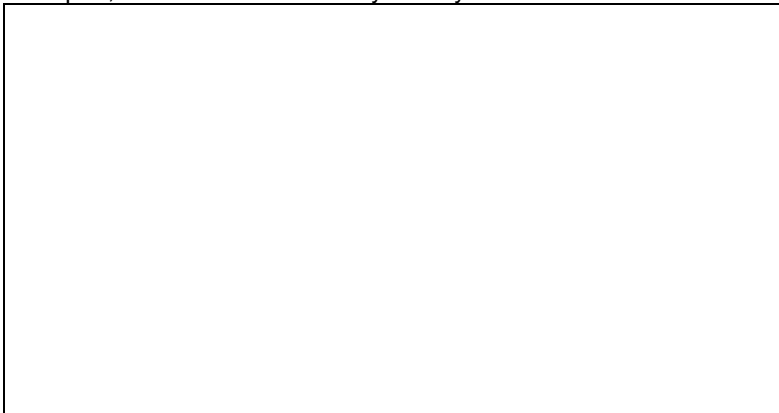

**MANUFACTURER:**



Tokyo office  
1-10-1 Kandanshiki-cho, Chiyoda-ku, Tokyo 101-0054, Japan  
TEL: +81-3-6273-7652(English) FAX: +81-3-6273-7944  
URL: <http://www.nichiryo.co.jp/>  
E-mail: [i-sales@nichiryo.co.jp](mailto:i-sales@nichiryo.co.jp)

2014.Ver.1